



Pompe volumetriche periferiche ad aspirazione laterale, adatte a piccoli impianti domestici e per modeste applicazioni industriali; caratterizzata da un notevole rapporto tra le prestazioni offerte e la potenza richiesta; chiusura del corpo in ottone, a riduzione del rischio di bloccaggio.

Peripheral positive displacement pumps with side suction for small household systems and simple industrial applications; characterised by a considerable ratio between performance and required output; frontal brass insect avoiding the risk of blockage.

Bombas volumétricas periféricas de lateral apropiadas para pequeñas instalaciones domésticas y para modestas aplicaciones industriales; caracterizadas por una notable relación entre las prestaciones que ofrecen y la potencia solicitada; extremidad del cuerpo de latón para reducir el riesgo de bloqueo.

Pompes volumétriques périphériques à aspiration latérale, aptes aux petites installations domestiques et pour des applications industrielles légères; caractérisées par un excellent rapport entre performances offertes et puissance demandée; la fermeture du corps est en laiton, afin de réduire le risque de blocage.

CARATTERISTICHE COSTRUTTIVE / CONSTRUCTION FEATURES
CARACTERÍSTICAS CONSTRUCTIVAS / CARACTÉRISTIQUES D'EXÉCUTION

Corpo pompa Pump body	ghisa e ottone cast iron and brass
Cuerpo bomba Corps de pompe	fundición y latón fonte et laiton
Supporto motore Motor bracket	ghisa cast iron
Soporte motor Support moteur	fundición fonte
Girante Impeller	ottone brass
Rodete Turbine	latón laiton
Tenuta meccanica Mechanical seal	ceramica-grafite ceramic-graphite
Sello mecánico Garniture mécanique	cerámica-grafito céramique-graphite
Albero motore Motor shaft	acciaio AISI 416 stainless steel AISI 416
Eje motor Arbre moteur	acero AISI 416 acier AISI 416
Temperatura del liquido Liquid temperature	0 - 90 °C
Temperatura del liquido Température du liquide	
Pressione di esercizio Operating pressure	max 8 bar
Presión de trabajo Pression de fonctionnement	

MOTORE / MOTOR / MOTOR / MOTEUR

Motore 2 poli a induzione 2 pole induction motor	3~ 230/400V-50Hz 1~ 230V-50Hz con termoprotettore with thermal protection
Motor de 2 polos a inducción Moteur à induction à 2 pôles	con protección térmica avec protection thermique
Classe di isolamento Insulation class	F
Clase de aislamiento Classe d'isolation	
Grado di protezione Protection degree	IP44
Grado de protección Protection	



TYPE	TRUCK		CONTAINER	
	PALLET (cm)	N° pumps	PALLET (cm)	N° pumps
PL 50	85x110x170	207	85x110x190	220
	80x120x170	198	80x120x190	230
PL 100	85x110x170	105	85x110x190	135
			80x120x170	136

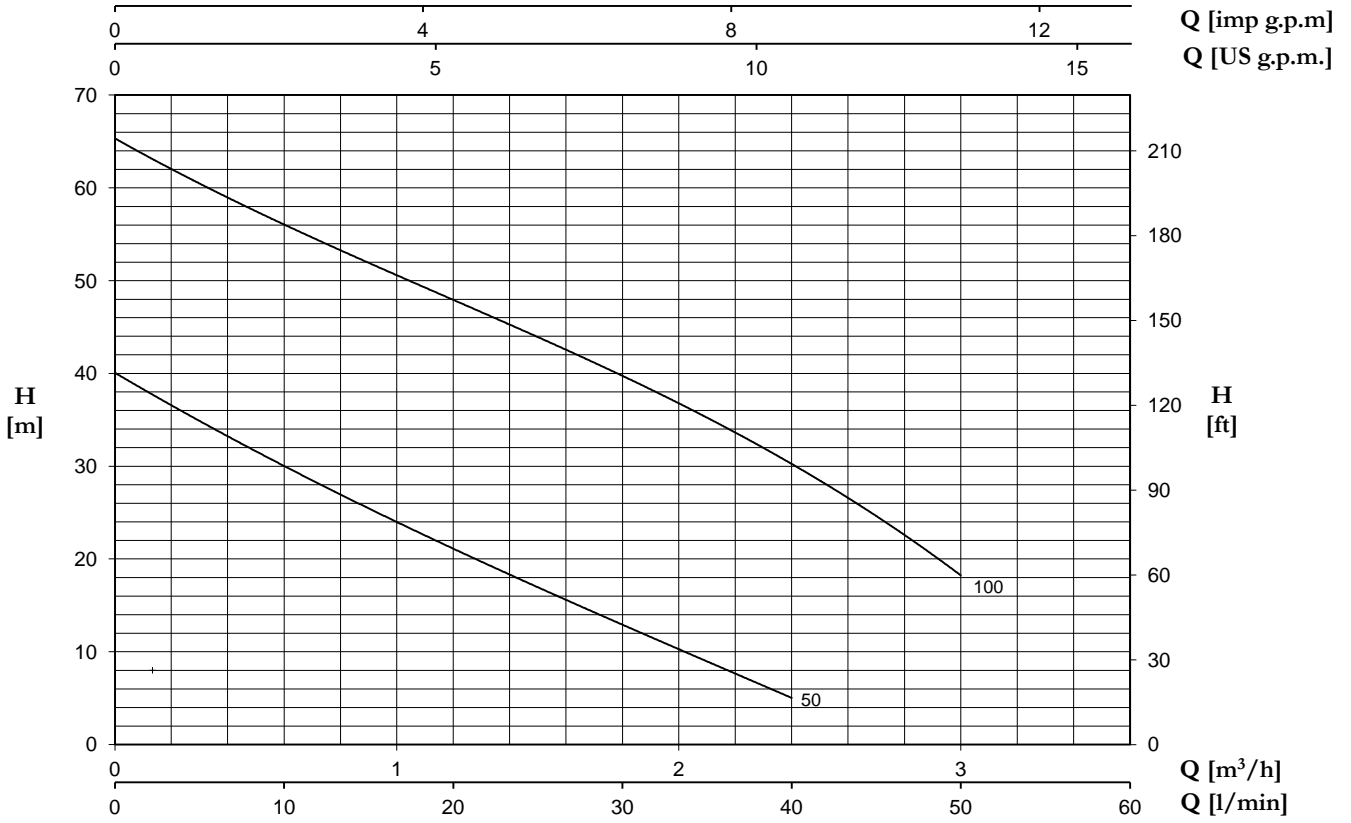

TYPE		P2		P1 (kW)		AMPERE		Q (m³/h - l/min)					
1~	3~	(HP)	(kW)	1~	3~	1~	3~	0,3	0,6	1,2	1,8	2,4	3
						1x230 V 50 Hz	3x400 V 50 Hz	H (m)					
PL 50	PL 50 T	0,5	0,37	0,5	0,5	2,3	1	35	30	21	13	5	-
PL 100	PL 100 T	1	0,74	1,11	1,13	5,2	2	61	56	48	39	31	18

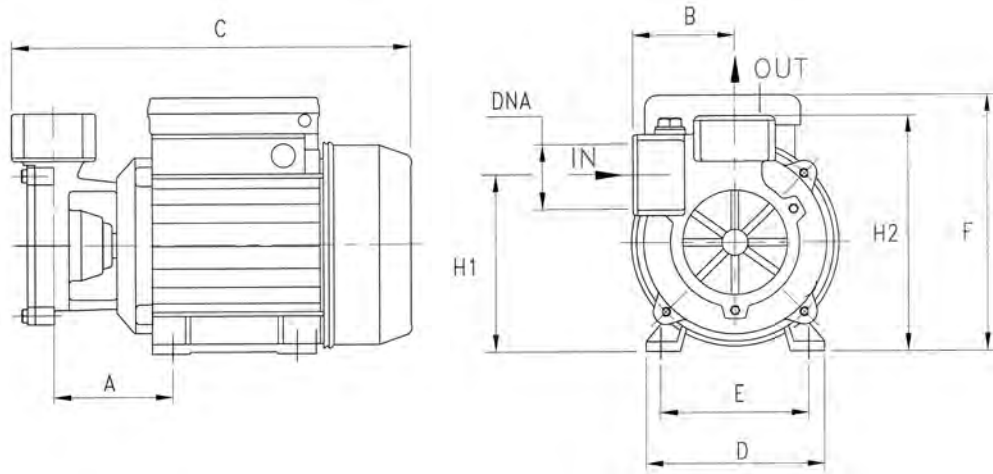

TYPE	DIMENSIONS (mm)													Kg
	A	B	C	D	E	F	H1	H2	DNA	DNM	I	L	M	
PL 50	67	60	235	120	97	165	105	140	1" G	1" G	265	145	165	5.6
PL 100	71,5	60	263	135	112	172	124	156	1" G	1" G	310	185	195	9.5