

# SWITCHMATIC 2T

---



## ADVANCED SETTINGS



Risk of damaging the pressure assemblies and/or the plant.



Risk by electric shock.



Risk for people and/or objects.



## GENERAL

Read carefully the instructions before installing this unit. Verify the technical characteristics of the motor in order to assure the compatibility with the device.

## DESCRIPTION (diagram A)

SWITCHMATIC 2T is an electronic pressure switch with integrated digital manometer. It manages the start and stop of a three-phase pump up to 4kW (5,5 HP). Cut-in and cut-out pressures are easily adjustable through the users control panel.

Wiring is analogous to the traditional electromechanical switch.

It can operate as a differential pressure switch and as reverse pressure switch.

Unit SWITCHMATIC 2T in addition to all the features of the basic SWITCHMATIC includes instantaneous reading of current drawn. This patented system controls and manages the overcurrent, dry-run operation and fast-cycling.

Unit SWITCHMATIC 2T in addition to all the features of individual assembly includes the option to be synchronized to another unit SWITCHMATIC 2T managing and protecting 2 pumps operating in cascade with alternated starting sequence.

## CLASSIFICATION AND TYPE

According to IEC 60730-1 and EN 60730-1 this unit is a control sensor device, electronic, independent assembly, programming type A with action type 1B (microdisconnection). Operating value: I <20% I learned. Pollution degree 2 (clean environment). Rated impulse voltage: cat II / 2500V. Temperatures for ball test: enclosure (75) and PCB (125).

## OPERATING CHARACTERISTICS

- Adjustable cut-in and cut-out pressures.
- Integrated digital pressure gauge with bar and psi indication.
- Inner pressure transmitter.
- Dry-run protection: through the instantaneous current consumption in case of.
- Overload protection.
- Overvoltage protection.
- Undervoltage protection.
- ART Function (Automatic Reset Test). When the device has stopped the pump by the intervention of the dry-running protection system, the ART tries, with scheduled basis, to re-start the pump in order to restore the water supply. See "ART. Automatic reset function". Must be activated in the step 5 of the ADVANCED MENU (Ar1).
- Fast cycling: when the hydropneumatic tank has lost too much air and, consequently, frequent start-stop cycles are produced this alarm is activated and is delayed the start of the pump. Activated (rc2).
- Manual start push-button (ENTER).
- 3 operation modes: differential, reverse and synchronized.
- Control panel with 3-digit display, LED indicator lights and push-buttons.
- Available settings:
  - Stand-by mode.
  - Minimum period between fast cycles.
  - Start and stop delay.

## TECHNICAL CHARACTERISTICS

- Rated motor power: 4,4kW (5,5HP)
- Power supply: ~3 x 230-400 Vac
- Electric outlet: ~3 x 230-400 Vac
- Pressure max. 1,2 MPa
- Frequency: 50/60Hz
- Max. current: 10 A
- Protection degree: IP55
- Max water Temperature: 40°C
- Max environment Temperature: 50°C
- Maximum relative humidity: 80% (31°C) - 50% (40°C)
- Cut-in range (start pressure) 0,5÷11,5 bar
- Cut-out range (stop pressure) 1÷12 bar
- Max. differential (Pstop-Pstart) 11,5 bar
- Minimum differential (Pstop-Pstart) 0,5 bar
- Factory setting (start/stop) 3/4 bar
- Hydraulic inlet G1/4" Female - Rotative nut
- Net weight (without cables) 0,654 kg

## HYDRAULIC INSTALLATION (diagram A)



SWITCHMATIC 2T equipment must be threaded to a fitting G1/4" male at the pump's outlet.

Before connecting the SWITCHMATIC 2T verify that the hydraulic system is properly installed, especially if the hydropneumatic tank is pressurized.

## ELECTRIC CONNECTION (diagram B)



The electric connection must be performed by qualified personal in compliance with regulation of each country. Before doing manipulations inside the device, it must be disconnected from the electric supply. Wrong connection could spoil the electronic circuit.

**The manufacturer declines all responsibility in damages caused by wrong connections.**

When carrying out the electrical connection it is compulsory to use a differential switch of high sensitivity: I = 30 mA (class A o AC). It is compulsory to use a magnetothermic switch adapted at the motor load.

Check if power supply is between 110-400V.

If you have purchased the unit without cables follow diagram B:

- Use cables type H07RN-F 4G1 or 4G1,5 with section enough to the power installed.
- Do the pump connection U, V, W and ⊕
- Do the power supply connection L1, L2, L3 and ⊕.
- The earth conductor must be longer than the others. It will be the first one to be mounted during the assembly and the last one to be disconnected during the dismantling. **The earth conductors connections are compulsory!**

## CONTROL PANEL (diagram C)

The meanings of the different control panel elements are summarized on the following tables, where:

- O means lit LED light.
- ((O)) means slow-flashing.
- (((O))) means fast-flashing.

DISPLAY	ACTION
OPERATION MODE	Is showed on screen instantaneous pressure or instantaneous current consumption
ADJUSTMENT MODE	Is displayed on screen the adjusted start pressure blinking. Is displayed on screen the adjusted stop pressure blinking. Is displayed the adjusted rated current blinking.
ALARM MODE	Is displayed the alarm code
STAND-BY MODE	Are displayed 3 flashing dots
BASIC CONFIGURATION MODE	Is displayed the sequence of basic configuration parameters
ADVANCED CONFIGURATION MODE	Is displayed the sequence of advanced configuration parameters

LEDS	STATE	MEANING
bar	O	It indicates the instantaneous pressure in bar
	((O))	It indicates the instantaneous pressure in bar + pump operating
psi	O	It indicates the instantaneous pressure in psi
	((O))	It indicates the instantaneous pressure in psi + pump operating
A	O	It indicates the instantaneous current consumption in Ampere units
	((O))	Pump ON
START	O	Is displayed the start pressure
	((O))	Adjusting start pressure
STOP	O	Is displayed the stop pressure
	((O))	Adjusting stop pressure
	O	Ratified dry-running or overload alarms
	((O))	Dry-running alarm performing ART or overload alarm performing any of the 4 restore attempts
	(((O)))	Fast-cycling alarm
V	O	It indicates the instantaneous voltage consumption in voltage units

P-BUTTON	TOUCH	ACTION
	click!	<b>From state ON:</b> unit OFF. <b>From state OFF:</b> the pump starts and keeps operating until reaching Pstop. <b>From any configuration MENU:</b> the parameter value is accepted.
	HOLD DOWN	<b>From state ON:</b> unit OFF. <b>From state OFF:</b> the pump starts and keeps operating until the push-button is released.
	click!	Pstart is displayed on the screen for 3 seconds.
	3"	Pstart adjustment mode.
	click!	Pstop is displayed on the screen for 3 seconds.
	3"	Pstop adjustment mode.
	click!	Is displayed on the screen instantaneous current consumption. If it is already displayed then we switch to instantaneous pressure view.
	3"	Rated current adjustment.
	click!	Is displayed on the screen instantaneous voltage. If it is already displayed then we switch to instantaneous pressure view.
	3"	Adjust rated voltage between different options: 110V, 125V, 220V, 230V, 380V, 400V.

## STARTUP

Before starting the device please read the previous sections, especially "Hydraulic Installation" and "Electrical connection".

Follow next steps:

- Set the power supply voltage.
  - Press during 3 seconds.
  - The voltage value is displayed on screen, LED V lights up and display is flashing.
  - By mean of and is adjusted the power supply voltage. See Note 1.
  - Press for validation.
- Set the pump rated current intensity value.
  - Press during 3 seconds.
  - The current intensity value is displayed on screen, LED A lights up and display is flashing.
  - By mean of and is adjusted the rated current reflected in the characteristics plate of the motor. See Note 2.
  - Press for validation.
- Start the device by pressing .
- Set the cut-in (start) pressure:
  - Press during 3 seconds.
  - The start pressure value is displayed on screen, LED START lights up and display is flashing.
  - By mean of and is adjusted the start pressure from 0,5 to 11,5 bar (+ version=11 bar).
  - Press for validation.
- Set the cut-out (stop) pressure:
  - Press during 3 seconds.
  - The stop pressure value is displayed on screen, LED STOP lights up and display is flashing.
  - By mean of and is adjusted the stop pressure from 1 to 12 bar (+ version=12 bar).
  - Press for validation.
- The unit is ready to operate but more optional adjustments can be set through basic and advanced MENUS. See the next chapter.

**Remark 1: it is important to introduce exactly the power supply voltage specified on the nameplate of the pump.**

**Remark 2: it is important to introduce exactly the rated current specified on the nameplate of the pump.**

## BASIC MENU +

- Press simultaneously + during 5 seconds.
- By mean of or the values can be changed.
- Press for validation.
- The parameters sequence is:

it	TYPE	SYSTEM REACTION	FACTORY SETTING
1	BAR P	We can select the pressure units displayed between bar and psi.	bar
2	rc0 rc2	Fast-cycling alarm: - rc0: alarm unabled. - rc1: activated, when hammering is detected it is delayed the start in order to protect the pump. - rc2: alarm is activated and the pump is stopped upon detection.	rc2
3	r.01 r.99	Only if fast-cycling alarm has been activated in the previous step (rc1&rc2). It can be choosed the maximum time period between 3 consecutive starts that will be considered fast cycling (between 1 sec. and 99 sec.)	3 seconds
4	Sb0 Sb1	Stand-by mode activated (Sb1), for low power consumption, or unabled (Sb0).	Sb0

## ADVANCED MENU + +

- Press simultaneously + + during 5 seconds.
- By mean of or the values can be changed.
- Press for validation.
- The parameters sequence is:

it	TYPE	SYSTEM REACTION	FACTORY SETTING
1	nc no	Select the operation MODE as a conventional pressure switch (nc = normally closed) or reverse (no = normally open). *see remark 3	nc
2	E00 E01/02	Select the operation mode Individual (E00) or Master/Slave (E01/E02) in case of be assembled in groups of two pumps.	E00
2.1	d.05 d.1	Sets the minimum gap between Pstart 1 and Pstart 2 and/or Pstop 1 and Pstop 2.	d.05
3	ct0 ct9	Sets a time delay between 0 and 9 seconds to the start (is not available in synchronized operation mode).	ct0
4	dt0 dt9	Sets a time delay between 0 and 9 seconds to the stop.	dt0
5	Ar0 Ar1	Activation of the automatic restore system ART (Ar1) o disable (Ar0).	Ar0
6	P0.0 Px.x	It allows setting a minimum operating pressure under which the device would determine dry-running operation.	0 bar 0 psi
6.1	t05 t99	Set the time period between 5 and 99 seconds below the minimum operating pressure that will be considered a dry-running operation.	20"
7	c10 c30	It allows setting a % of nominal current above which the device will activate the overcurrent protection.	c20
8	rS0 rS1	If we change rS0 to rS1 and push ENTER default values are restored.	rS0

### Remark 3:

**By choosing "no" (normally open) it will operate as an auxiliary pressure control element in the suction of the pump. It will restart when the suction pressure reaches the configured PStart.**

### Example:

- PStop: 0,9 bar
- PStart: 1,2 bar

## SYNCHRONISATION

SWITCHMATIC 2T can be synchronized to another unit SWITCHMATIC 2T managing and protecting 2 pumps operating in cascade with alternated starting sequence. Next steps must be followed:

- GO TO ADVANCED MENU: + +
- In **step 2**: select E01 in a unit (this one will be the master) and select E02 in the other unit (this one will be the slave).
- In **step 3**: select **identical** parameters of gap between pressures d.XX. This is the difference between the starting pressure of main and auxiliary pumps, it is also the difference between stop pressures of both pumps.

**Differential (dX.X) = Pstop - Pstart ≥ 1 bar**  
**Gap (d.XX) = Pstop1 - Pstop2 = Pstart1 - Pstart2**

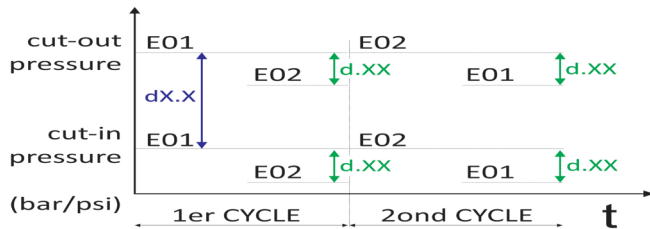

- Press repeatedly until exit the ADVANCED MENU.
- SET **identical** cut-in and cut-out pressures in both units.
- To optimize the synchronization, the minimum difference between the start and stop pressures must be at least 1 bar.**
- Press in order to disable the units. Is displayed "OFF".
- Press again in both units in order to activate the synchronization.

**Remark 4: after 10 cycles the unit configured E01 will display pressure and the unit configured E02 will display current in Amps.**

## PRESSURE SENSOR CALIBRATION

In case of wrong lecture of the pressure sensor it can be adjusted again. For the pressure sensor calibration is necessary to have a pressure gauge in the installation. Proceed following next steps:

### ZERO REGULATION

- Open the taps living the hydraulic net without pressure.
- Press simultaneously the buttons and until the display show 0.0 flashing.
- Press to validate.

### FULL SCALE

- Start the pump and close all the taps to pressurize the installation and reach the cut-out pressure. (If the pump does not start, please hold the button to reach the cut-out pressure)
- Press simultaneously the buttons and till the display flashes with a figure.
- Adjust the pressure with the arrows push-buttons until the value on the display matches with the pressure reading.
- Press to validate.

**Remark 5: pressure sensor decalibration should not be a normal event. If it is frequently repeated contact the technical service.**

## WARNINGS AND ALARMS

COD.		DESCRIPTION	SYSTEM REACTION
A01		DRY-RUNNING  (( O ))	When is detected a dry-run operation the pump is automatically stopped. By mean of ENTER the normal operation can be manually restored.  After the activation of the dry-running alarm if the Automatic system reset (ART) is enabled, a first attempt at 5 minutes and then an attempt every 30 minutes for 24 hours is performed in order to restore the normal operation. This alarm can also be reset manually with the ENTER push-button. If the alarm persists after 24 h we find a definitive alarm.
A11		DRY-RUNNING (BY MINIMUM PRESSURE)	Is displayed during normal operation if the pressure is below the minimum pressure (Px.x) - previously set - during a period (txx) - also previously set - in the ADVANCED MENU. If at any time the pressure exceeds the minimum pressure, the operation is restored automatically and the alarm is cleared. Normal operation can also be restored manually by pressing ENTER.
A02		OVERLOAD  (( O ))	Overcurrent alarm is activated when the nominal pump current is exceeded. 4 automatic reset attempts prior to the final alarm are performed. During the attempts display will show current. Normal operation can also be restored manually by pressing ENTER.
A04		FAST CYCLING	This alarm can be disabled or activated in the BASIC MENU. The alarm is activated when 3 consecutive cycles occur in a range lower than the set time (between cycle and cycle). If it has been activated rc1, this alarm does not stop the normal operation but are added 5 seconds to the start delay in order to protect the electric pump. If it has been activated rc2, the pump is stopped. To RESET the normal operation press ENTER.
A05		DAMAGED PRESSURE TRANSMITTER	CONTACT WITH YOUR SUPPLIER.
A08		OVERVOLTAGE  (( O ))	Overvoltage alarm is activated when the power supply voltage is exceeded. 4 automatic reset attempts prior to the final alarm are performed. During the attempts display will show . Normal operation can also be restored manually by pressing ENTER.
A09		UNDERVOLTAGE  (( O ))	Undervoltage alarm is activated when the power supply voltage is under the minimum. 4 automatic reset attempts prior to the final alarm are performed. During the attempts display will show . Normal operation can also be restored manually by pressing ENTER.

## EC STAMENT OF COMPLIANCE

COELBO CONTROL SYSTEM, S.L.  
 States, on our own responsibility, that all materials here with related comply with the following European Directives: 2014/35/EU. 2014/30/EU. 2011/65/EU.

Name: - SWITCHMATIC 2T

Standards : EN-60730-2-6, EN-60730-1, EN-61000-6-1, EN-61000-6-3, IEC-60730-1, IEC-60730-2-6

F. Roldán Cazorla  
 Director Técnico  
 04/05/2016

COELBO CONTROL SYSTEM, S.L.  
 Ctr de Rubí, 288 - Pl. Can Guitard  
 08228 Terrassa - BARCELONA (SPAIN)

DIAGRAM A:

INDIVIDUAL

**MANDATORY USE OF  
PRESSURE TANK**

~3x400 V  
~3x230 V

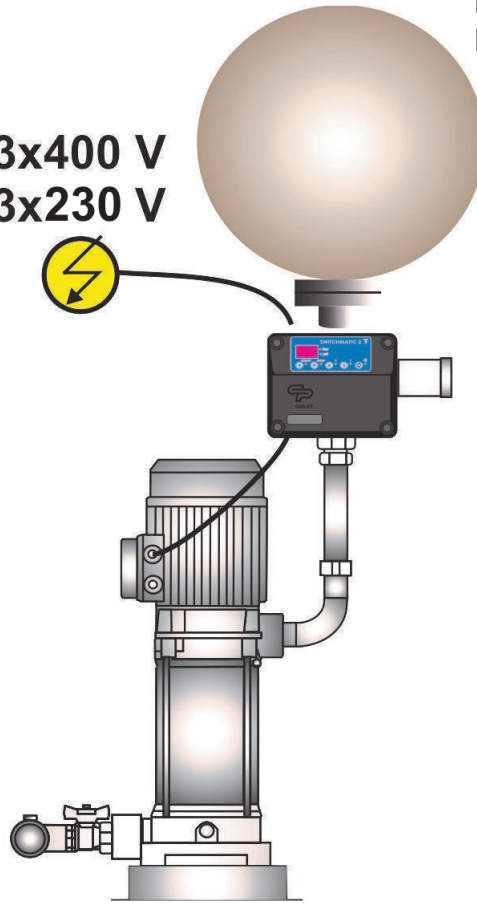

GROUPAL

**MANDATORY USE OF  
PRESSURE TANK**

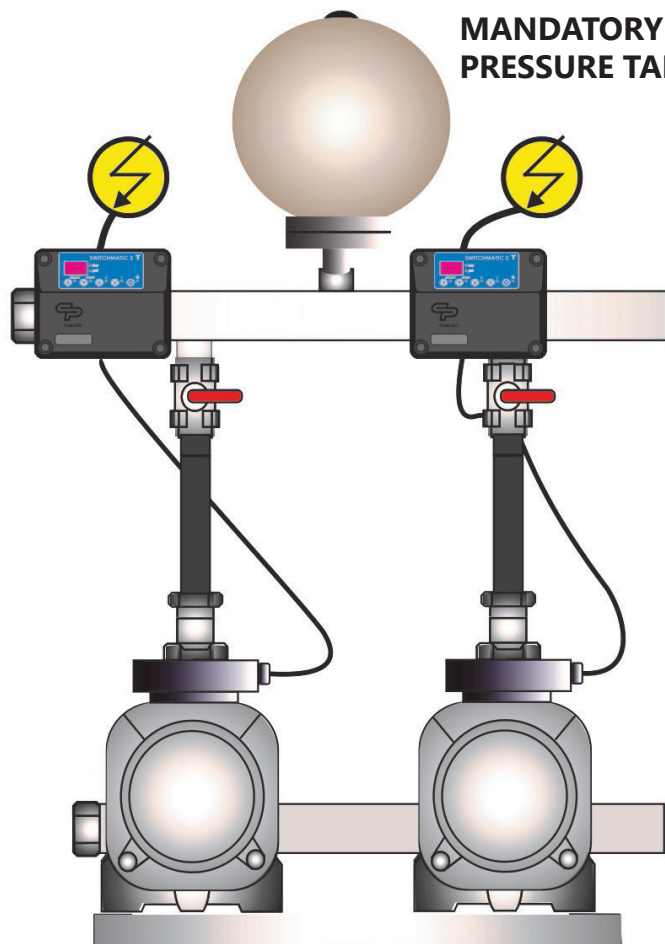



DIAGRAM B:

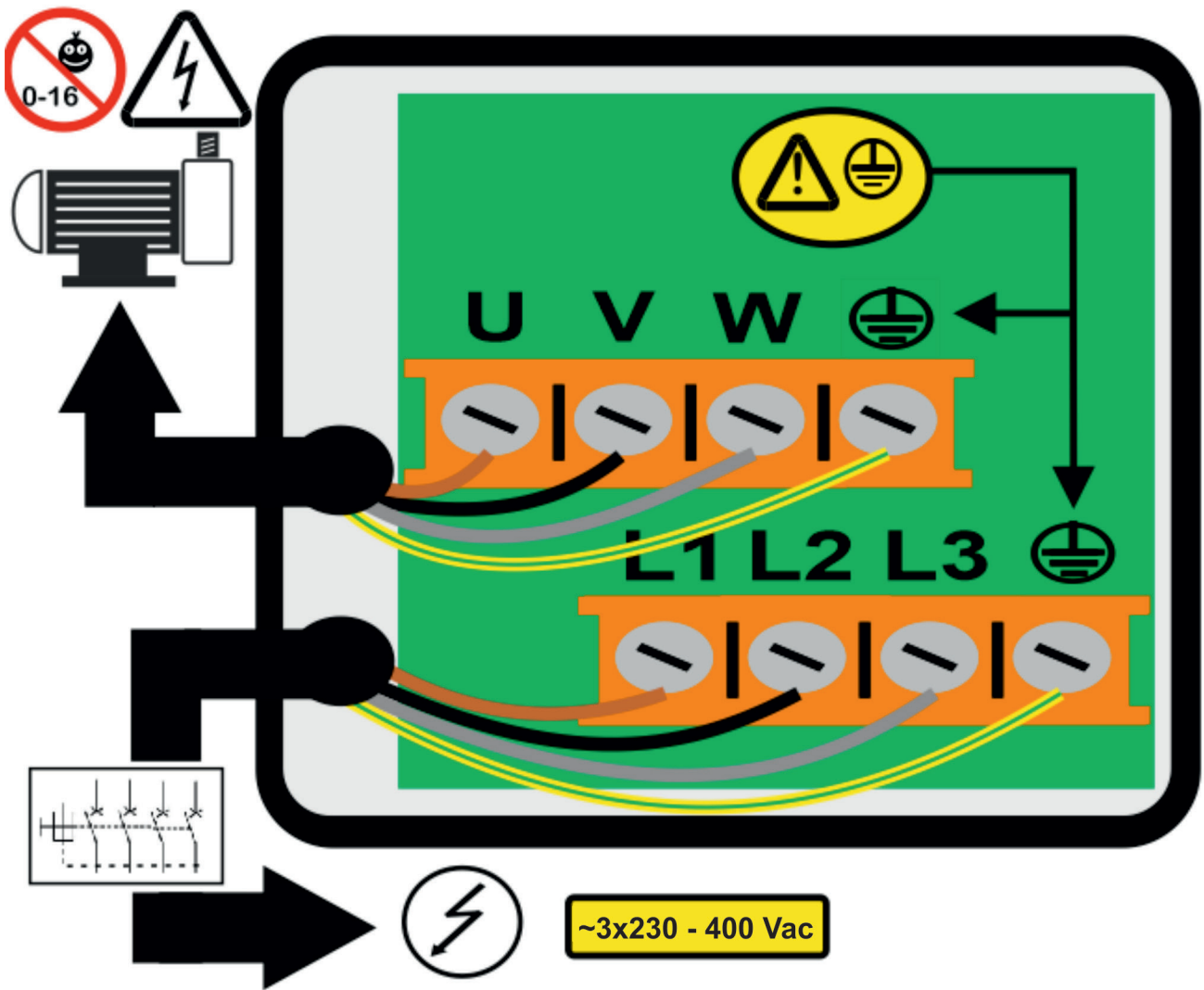
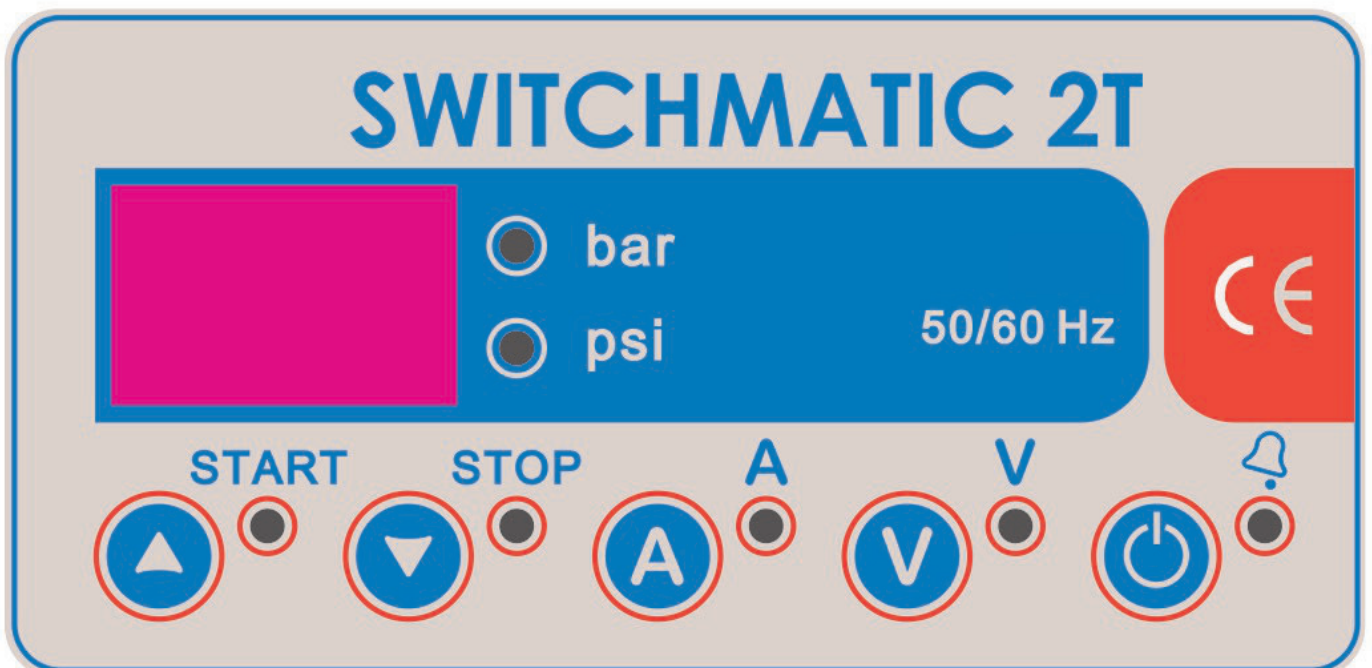

DIAGRAM C:



DIMENSIONS:

